



Intumescent Fire Seals Association

The Role of Fire Resistant and Smoke Containment Air Transfer Grilles in Building Ventilation Systems



CONTENTS

Introduction	page 1
Role of air transfer grilles	page 1
Definitions and functions	page 1
Fire performance requirements	page 2
Varieties of air transfer grilles	page 3
Recommended installation methods	page 6
Dimensional and positional limitations	page 6
Non-fire performance requirements	page 6
Test standards	page 7
Conclusion	page 8
About IFSA	page 8



INTRODUCTION

This IFSA Information Sheet is intended to give guidance to ventilation system designers, product specifiers, building control authorities, fire prevention officers, builders and installers on the correct use of fire and smoke containment air transfer grilles. It describes their role, variations and their function together with the performance requirements and relevant test standards.

Role of air transfer grilles

Air transfer grilles are increasingly used as part of a system design to improve the air quality and temperature control in buildings by allowing greater controlled air circulation.

Although they are usually used in conjunction with fan assisted ventilation ducts they are sometimes used as the sole means of providing ventilation particularly where space limitations prohibit the use of ductwork.

The increasing importance to reduce construction and energy costs will motivate ventilation system designers to dispense with fans and ductwork and more frequently employ natural ventilation and 'stack effect' as the prime air mover through easily installed and maintained air transfer grilles.

Fire protection is often provided by creating pressure variations within a building to inhibit the rapid spread of fire, smoke and hot gases within. This is made possible by the use of fire and smoke sealed doors that allow the ventilation system to create a differential pressure from one side of a door to the other. Any hot gases egressing past the door seals will flow from the higher pressure side of the door to the lower pressure side. Selecting appropriate pressure differentials for different parts of the building therefore, will greatly improve the containment of fire spread and keep escape routes tenable for a longer period of time. For example hotel corridors are usually maintained at higher pressure than the adjoining rooms or fire compartments. Since most hotel fires originate in the kitchen or guest rooms

the pressure differential will inhibit the spread of fire into the corridors.

A ventilation system designer having decided on the appropriate pressure differentials required in a building will need to calculate the necessary volumetric air flow to achieve the differentials allowing for ambient air leakage inherent in each part of the building.

If this air flow is to circulate through air transfer grilles, such grilles must be carefully selected to allow the appropriate volume of air whilst creating the specified pressure differentials. Occasionally the necessary pressure differential is so critical that an air transfer grille which incorporates a pressure control device may be needed. This will compensate for fluctuations in general air movement in the rest of the building caused by opening doors or windows etc. A typical example is between a hospital operating theatre and corridors or adjoining rooms.

Until comparatively recently the use of air transfer grilles has been limited by the potential compromise they posed to controlling the spread of fire and smoke in the event of fire in a building. However, the creation of effective fire and smoke containment air transfer grilles with good aerodynamic performance has greatly enhanced their versatility.

It is essential however to select grilles that are appropriate to the required application in terms of: fire resistance, smoke leakage, volumetric flow, pressure drop, reliability and dimensional compatibility with the supporting construction. In the UK air transfer grilles are not generally required to satisfy the insulation criteria, especially when fitted in doors, but many European states do require the insulation criteria of the fire resistance test to be satisfied.

Definitions and Functions

Air transfer grille – A non-fire rated device which provides a security and privacy screen for an aperture through which air is passed as part of a ventilation system. The device may incorporate a means of diffusing the air stream.



Applications are restricted to their installation in those elements of building construction that are **not part of the boundary of a fire compartment or fire protected route** and includes: walls, ceilings, doors and low velocity duct termini.

Possible fire performance ratings: None

Fire containment air transfer grille – A device that permits the passage of air but which provides a security and privacy screen which, when activated by a rise in temperature of the air stream provides containment of fire and hot gases in addition to the normal function of an air transfer grille but is **not intended to control smoke at ambient temperature**. It is therefore acceptable to install this type of device in a FD30 or FD60 fire door **but not in an FD30S or FD60S fire door**. – Possible fire performance ratings – EI (integrity and insulation).

E – In excess of or no less than 30 mins.

In excess of or no less than 60 mins.

In excess of or equal to 90 mins.

I – In excess of or equal to 30 mins.

In excess of or equal to 60 mins.

Fire and ‘cold’ smoke containment air transfer grille - A device which functions as a normal air transfer grille, which in fire conditions is activated, normally by the activation of intumescent materials, to seal off the air path by one of two separate methods:

- a) provides electro-mechanical activation of physical barriers designed to contain ambient temperature smoke by an interface with smoke detectors via a fire alarm panel
- b) restricts fire and the passage of hot gases when activated by a rise in temperature of the air stream

This type of device must be used where air transfer is needed between fire compartment boundaries but where the spread of ambient or ‘cold’ smoke will pose a threat to life safety. For example: **this type of device must be used** where air transfer is necessary through **an FD30S or FD60S fire door**.

Possible fire performance ratings:

EIS (integrity, insulation and smoke) for fire ratings see Fire containment air transfer grilles above). For smoke containment performance see Fire performance requirements – Smoke leakage below.

Stack effect – Stack effect is a temperature induced method of generating pressure differentials. When there is a temperature difference between two adjacent volumes of air the warmer air will have lower density and be more buoyant thus will rise above the cold air creating an upward air stream. Forced stack effect in a building takes place in a traditional fire place. Passive stack ventilators are common in most bathrooms and other enclosures without direct access to the outdoors.

Fire Performance Requirements

Fire integrity (ability to resist spread of combustion gases and flames)

A fire rated air transfer grille should have the same period of fire integrity as that of the supporting construction into which it is installed, for example if fitted to an FD60 fire door, the fire integrity of the air transfer grille should be at least 60 minutes.

Care should be taken to ensure that the fire test evidence is appropriate to the intended application. For example an air transfer grille tested only in a masonry wall is not necessarily acceptable for installation in fire doors or duct termini.

Insulation (resistance to temperature rise on the unexposed face)

In the UK insulation performance is not currently a requirement when a grille is installed in a door leaf but many countries, including many of those in Europe, insist upon it. Where the grille is installed in a wall in the UK, the grille will need to satisfy the



insulation criteria, although it may be possible to justify a relaxation of these criteria with the relevant authorities if the risk can be accommodated.

Smoke leakage

Smoke leakage performance only applies to fire and smoke rated air transfer grilles where the leakage performance is measured at ambient temperature. The maximum allowable smoke leakage rate for door installations can be identified by reference to EN1634-3. This is not the case for walls [or in extreme cases ceiling] leakage since neither EN1364 -1 nor EN1364 – 2 require smoke leakage at ambient temperature to be measured. In the absence of such requirement it is recommended that a maximum leakage rate of 60 m³ per m² of air transfer grille aperture at 25 Pa should be adopted.

perforated metal plates and metal or plastic adjustable ‘hit & miss’ shutter plates.

Fire rated air transfer grilles –

Intumescent grilles react to heat in fire conditions when the major intumescent components swell up to many times their original size, sealing the gaps between them and thereby closing the air path. Intumescent grilles are now the most common type used but are available in many forms and using different types of intumescent material. The following table identifies the varieties of material and construction forms manufactured by IFSA members at the time of publication:

Varieties of Air Transfer Grilles

Standard Ventilation Air Transfer Grilles (Non-fire or smoke rated) – The most common type is manufactured from steel with horizontal louvres formed by ‘punching and pressing’.

Other varieties include assemblies of extruded aluminium or steel louvres, metal gauze,

Intumescent materials types	Sodium silicate	Intercalated graphite
Matrix of intumescent slats encapsulated in plastic	√	√
Matrix of intumescent slats encapsulated in metal foil	√	√
Matrix of non-encapsulated intumescent slats		√
Expanded metal grid coated with intumescent		√

When intumescent materials are activated by heat, they expand in volume and create a relatively impermeable mass of char which restricts the spread of flames and combustion gases including smoke. Generally, the impermeability is increased if the expanded intumescent is contained and compressed. Intumescent materials require little or no maintenance and cannot malfunction when heated, thereby providing a very reliable seal compared to mechanical devices.

For a detailed explanation of various intumescent materials, their function and behaviour in fire conditions please refer to IFSA Information Sheets 1 or 2.

Fire and smoke rated air transfer grilles –

Intumescent/electro-mechanical grilles are usually manufactured by combining an intumescent fire rated grille with a set of ‘hit & miss’ plates or rotating blades that are driven by



an electro-mechanical system which interacts with smoke detectors via the building fire alarm panel. This means that the grille can close off the aperture in two entirely separate ways, firstly by

smoke detection, which operates hit and miss plates and later by a rise in temperature, which causes the intumescent to activate, i.e. expand and close off the vents.

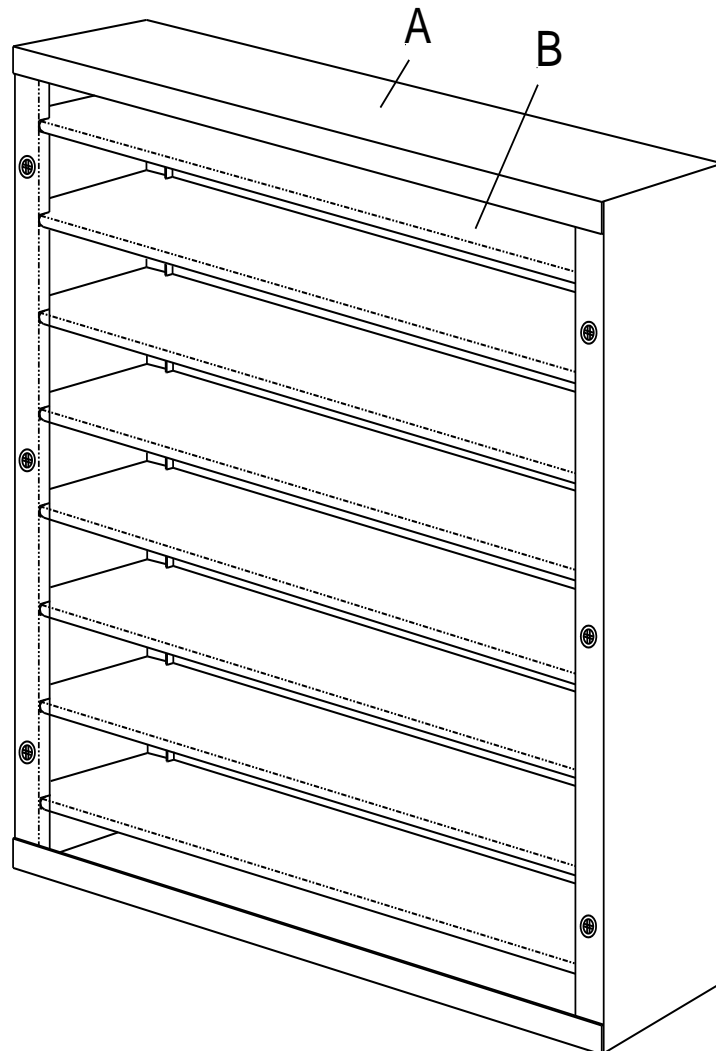

Figure 1

Typical wall mounted fire resistant air transfer grille

A – Rigid outer frame **B** – Encapsulated intumescent slats

NB: Air transfer grille of this type are usually protected by metal cover grilles on both faces, not shown on drawing



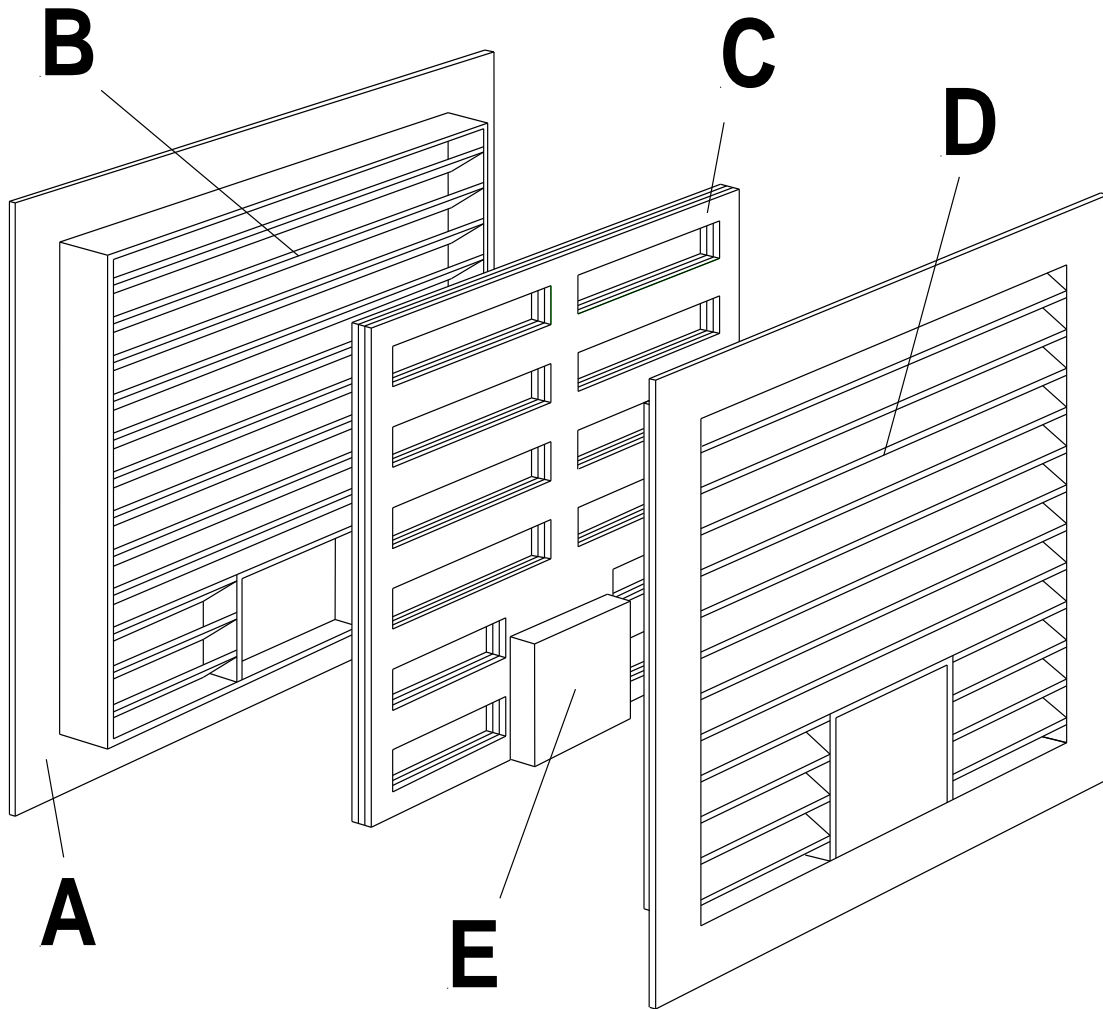

Figure 2

Typical door mounted intumescent fire resistant and smoke control air transfer grille

A - Mounting frame

B - Louvred encapsulated intumescent slats

C - Sliding cold smoke control 'hit & miss' plates

D - Louvred encapsulated intumescent slats

E – Electrically powered actuator interfaced with smoke sensors and alarm panel



Recommended installation methods

In timber door leaves

If the air transfer grille is to be installed at a relatively high level in the door it is important to check that the product specified has been successfully tested in the positive pressure zone of the furnace under a pressure differential of typically 20Pa. Normally the grilles are installed in the lower portion of a door which is the normal position for testing in a furnace.

When an aperture is cut into most modern fire door leaves made from composite timber products; flaxboard, chipboard, mdf, etc., to install a fire rated air transfer grille it is recommended to frame the internal faces of the aperture with a suitable dense hardwood strip to maintain the fire integrity of the door leaf. This strip must be glued in place by means of a non-thermally softening wood working adhesive, e.g. Resocincol or similar. Solid timber laminated covered doors do not require lining. Care must be taken to ensure that the grille is a close fit in the framed aperture and is adequately fire sealed around the edges. When installing smoke rated grilles which will need to be connected with electrical wiring drill sizes of the door leaf must be kept to a minimum. Reputable manufacturers of fire and smoke rated air transfer grille provide detailed installation and commissioning instructions and these should be closely adhered to.

In stud walls

If the air transfer grille is to be installed at a relatively high level above the floor it is important to check that the product specified has been successfully tested in the positive pressure zone of the furnace under a pressure differential of typically 20Pa.

Apertures cut into stud walls must always be lined with hardwood or large section softwood member frames in order to support the plasterboard and maintain the fire integrity of the wall. Such framing is best installed at the design stage. Reputable manufacturers of fire and smoke rated air transfer grille should provide detailed

installation and commissioning instructions and these should be closely adhered to.

Dimensional and positional limitations

The product selected should not exceed the dimensions (on any axis) from that which was tested or has otherwise been assessed as part of a field of application report.. Most fire tests for fire rated air transfer grilles will be conducted on a furnace with a positive pressure at the top and a negative pressure at the bottom with the neutral pressure axis nominally 500mm-900mm from the furnace floor. If the test evidence for a product is restricted to a particular vertical position (e.g. in the positive or negative zone) then it should only be employed where the same pressure is anticipated.

Care should also be taken to ensure that the aperture dimensions of the selected product do not exceed the maximum allowed in the associated structure. For example, if it is to be installed in a fire door the maximum aperture size should be established with the door manufacturer. Excessive dimensions of the aperture may result in premature integrity failure of the door in fire conditions as it could influence the amount that the leaf bows during a fire test. Similarly, if the grille is fitted too close to the edge of the leaf, this may also cause excessive distortion.

Non-Fire Performance Requirements

Volumetric flow

Ventilation system designers will have established the rate of air change required for each compartment zone of a building and should determine the pressure differentials that will ensue from the supply air and make up air arrangement where applicable. Fire engineers should also provide information concerning the pressure variables necessary in the building to conform to their fire safety strategy. Once the



two inputs are reconciled air transfer grilles can be selected which are compatible with the aerodynamic performance required in terms of volumetric flow, air velocity, pressure drop and air generated sound levels.

Acoustic considerations

There are two aspects of acoustic performance which should be considered, generated sound and transferred sound.

- a) Generated sound is the result of air passing through an air transfer grille causing rattling or reed type noise, particularly at higher velocities of air through the grille. This can be exacerbated by the design of the grille type. Also, in the case of fire and smoke containment air transfer grilles, sound can be generated by electro-mechanical actuation. Where these issues are likely to be of some consequence performance data should be sought from the manufacturer.
- b) Transferred sound is that which is carried from its source in the air that is passing through the grille. In the case of air transfer grilles to be installed in walls or other thick supporting constructions a combination of an acoustic chamber and a fire rated air transfer grille can usually be incorporated within the thickness of the construction to decrease the level of transferred sound.

Significant attenuation of transferred sound through grilles installed in fire doors is unlikely due to the thickness limitations of fire doors leaves.

Durability & Reliability

The environment in which the product will be located should be taken into account when specifying. Ensure that the product selected has evidence of its compatibility with the anticipated conditions such as humidity, moisture, high or low ambient temperatures, acidic or alkaline atmospheres, air velocities and pressure differentials.

Ensure that the product is sufficiently protected to remain functional when subjected to the mechanical abuse that may be encountered.

Establish what maintenance or cleaning regime will be necessary to ensure reliable performance both as an air transfer device and a fire/smoke containment system and implement the necessary measures.

Some early types of intumescent activated grilles are prone to premature clogging and deteriorate in humid conditions (such as honeycomb type grilles). Also they are difficult to clean effectively due to the fibrous nature of the materials used in their construction. These types of products are best avoided where reliability and durability is expected.

Test standards relevant to the performance of air transfer grilles

Loadbearing

Fire Resistance & Smoke Leakage Test Standards

BS 476 -21	Wall installations
BS 476 -22	Door installations and non-loadbearing walls
BS 476 – 31.1	Method of test for ambient smoke leakage
BS EN 1363 – 1	General requirement
EN1364 – 1	Wall installations
EN1364 – 2	Ceiling installations
EN1634 – 1	Door installations
BS EN1634 -3	Smoke control door and shutter installations
BS EN13501 – 2	Classification systems



Other related standards and guidance documents

EN1751	Ventilation in buildings – air terminal devices – aerodynamic testing
EN ISO 513	Acoustics – determination of sound levels from air terminals
EOTA TR01	Determination of impact resistance
EOTA TR024	Characterisation- Durability and FPC for reactive materials
ETAG 026-4	Fire stopping and sealing – Reactive air transfer grilles (When published)

CONCLUSIONS

It can be appreciated that fire and smoke restricting air transfer grilles already provide a versatile means of allowing the movement of air within buildings without the risk of excessive fire and smoke spread. Sadly there are many cases where products have been already selected and installed that are wholly inappropriate for the application.

The correct specification of the product is of paramount importance and whereas this document provides some guidance it highly recommended that further guidance specific to the application should be sought from those IFSA members who specialise in the manufacture of fire and smoke rated air transfer grilles supported by relevant up to date test evidence.

Links to members can be accessed from the IFSA web site: www.ifsa.org.uk.

Finally air transfer grilles, like any other technical product, will only perform adequately if their installation is conducted in accordance with the manufacturer's instructions by competent installers. It is therefore recommended that the guidance in Approved Document 'B' should be followed and that only third party accredited installers should be used to install these critical products.

There are a number of third party certification bodies that certify the installers of passive fire protection products, e.g. Warrington Certifire, IFC Certification Ltd.

INFORMATION ABOUT IFSA

The Intumescent Fire Seals Association (IFSA) is a trade association established in 1982 with the following objectives:

- To promote the life safety benefit associated with the use of intumescent and smoke seals
- To promote research and development into extending the areas where these benefits can be utilised
- To participate in the development of test procedures for fire protection products in BSI, CEN and ISO which are fair, repeatable and reproducible.

IFSA maintains close links with the fire community. The Secretariat is based at International Fire Consultants and receives technical advice from its Principal Consultant, Peter Jackman.

At the time of its formation, IFSA recognised the need for a simple standard test to compare the performance of intumescent fire seals for use in fire doorsets, which was free from the influence of other materials and constructional variations and yet subjected the intumescent material to the conditions which prevail in a full scale test. It, therefore, sponsored the development of such a test and this is now embodied in BS476: Part 23 (1987). Whilst the results of the test have a limited field of application, only being usable on single leaf, single action, latched doors of limited size and distortion characteristics, it does allow the sealing capability of intumescent seals to be compared without any influence from the leaf.

There is now an ISO equivalent test, i.e. BS ISO 12472: 2003.

Due to its repeatability the test method is being used successfully to evaluate the influence that real time ageing may have on the properties of intumescent fire seals produced by IFSA member companies. The programme is planned to investigate 25 years exposure to a variety of controlled and uncontrolled environments. Early findings showed no detectable visual decline and tests are being undertaken soon to confirm these findings.



A test programme undertaken in conjunction initially with DOE/BRE to produce standardise conditions for evaluating penetration seals formed the basis of the standard configuration incorporated in the CEN test procedure EN 1366-3 for evaluating seals for use with metal pipes. This configuration has been refined and now forms a draft technical report in ISO (DTR 10295-3) where a method of extrapolating the results of penetration sealing tests, using simple solid conductors, can be used to establish the field of application of intumescent sealants due to be published in 2010.

Fire stopping, service penetration sealing, fire doors and fire glass are all critical aspects of fire safe premises and under the new Regulatory Reform (Fire Safety) Order and the ongoing reliance on fire risk assessments, it is vital that risk assessors understand the role and function of these products. IFSA has produced a number of downloadable guides (electronic communiqués) to help risk assessors know and understand when a particular intumescent application is right or wrong, or how a risk may be controlled by the use of the correctly specified sealing product. These guides were commended by the ABE in the 2006 Fire Safety Award competition.

The move away from brickwork, blockwork and cast concrete forms of construction, towards a greater use of studwork and joisted walls, floors and ceilings, has left many of our fire separating constructions compromised by the fitting of electrical services (switches, plug sockets, concealed lighting, extract fans). IFSA has co-operated with the Electrical Safety Council (ESC), in the preparation of their guide, 'Electrical installations and their impact on the fire performance of buildings; Part 1, Domestic Premises'. This did win the ABE's Fire Safety Award in 2009.

Intumescent materials can seriously reduce the impact that such installations may produce.

Correctly fitted sealing systems make a greater contribution to life safety in a fire than almost any other measure. If you do nothing else to enhance life safety – at least seal up the building with fire and smoke seals, preferably from an IFSA Member because they take fire safety seriously



Intumescent Fire Seals Association

www.ifsa.org.uk

October 2010

CURRENT IFSA MEMBERS AND CONTRIBUTORS TO THE INFORMATION SHEET



TECHNICAL CONSULTANTS TO IFSA



**INTERNATIONAL FIRE
CONSULTANTS LTD**

Intumescent Fire Seals Association

20 Park Street
Princes Risborough
Buckinghamshire HP27 9AH
Tel: +44 (0)1844 276928
Fax: +44 (0)1844 274002
Web: www.ifsa.org.uk
Email: contactus@ifsa.org.uk



Intumescent Fire Seals Association
www.ifsa.org.uk

October 2010