

# INTUMESCENT TECHNOLOGY IN FIRE RESISTING GLAZING



# Fire Resisting Glazing

## INTRODUCTION

- UK design preference for glazed timber screens and doors.
- Intumescent seals provide frame integrity.
- Part of a system of critical components.
- Current fire tests: BS476 Parts 20 & 22 (Fire Tests on Building Materials and Structures).

# Fire Resisting Glazing

## Effect of fire on glass

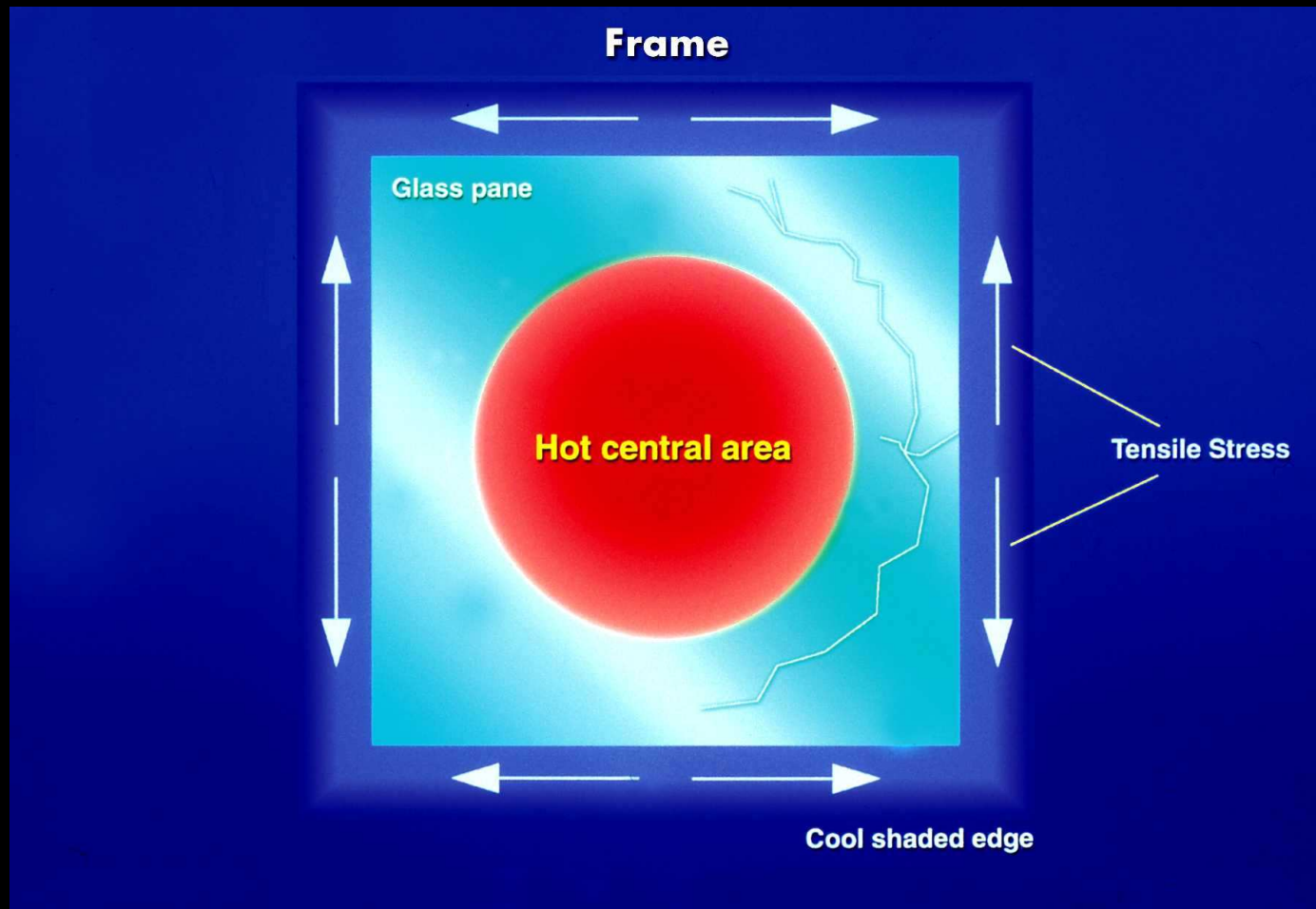

# Fire Resisting Glazing

## MECHANISMS OF FAILURE

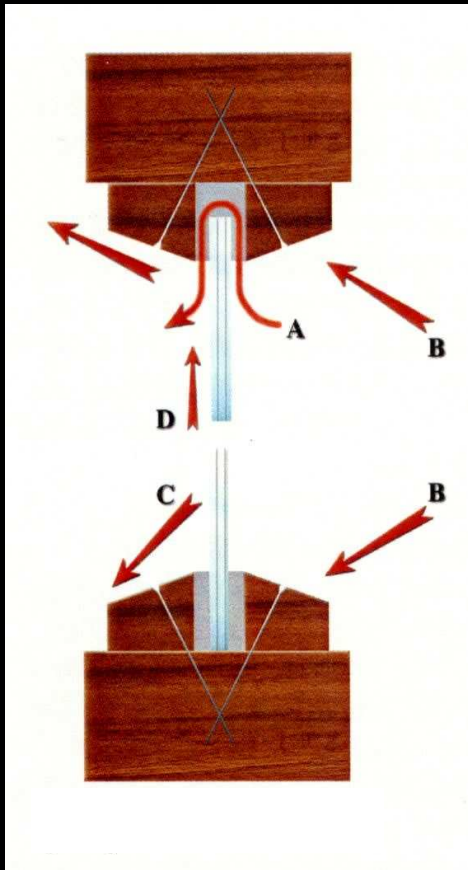

A: Integrity loss between beads and glass.

B: Deep fissuring of beads and frame.

C: Non-fire side ignition.

D: Slumping of glass.

# Fire Resisting Glazing

## General Points

- Smoke from rubber or plastic glazing seals compared with solely intumescent seals.
- Use tested timber/seal combination.

# Fire Resisting Glazing

## 30 Minute Glazing Detail



# Fire Resisting Glazing

## 30 Minute Glazed Fire Door

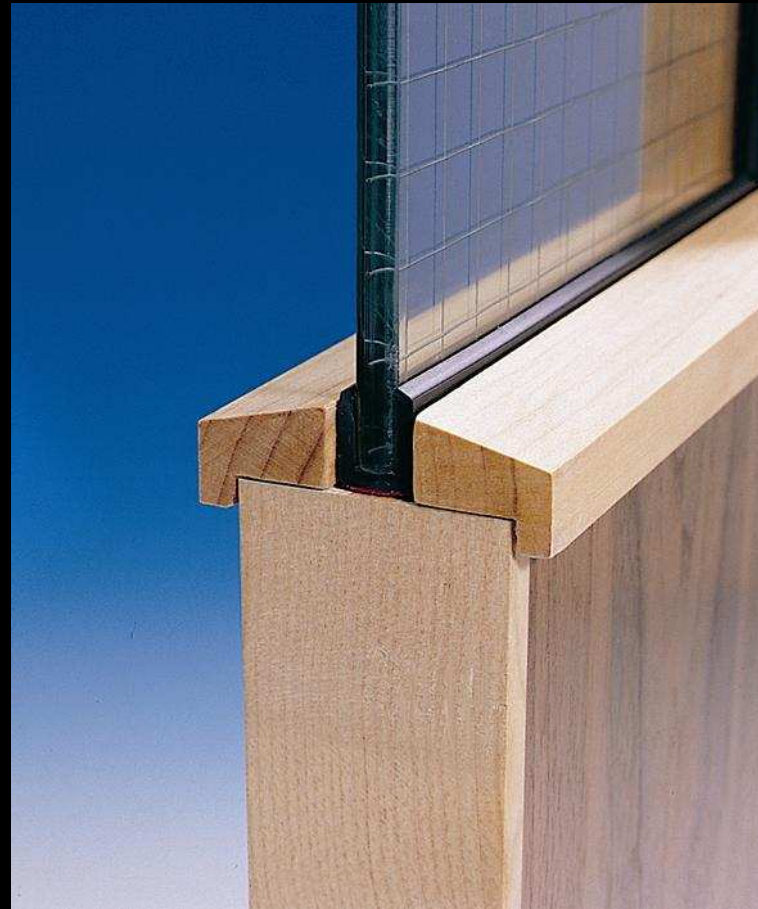

# Fire Resisting Glazing

## 60 Minute Glazing Detail



# Fire Resisting Glazing

## 60 Minute Glazed Fire Door

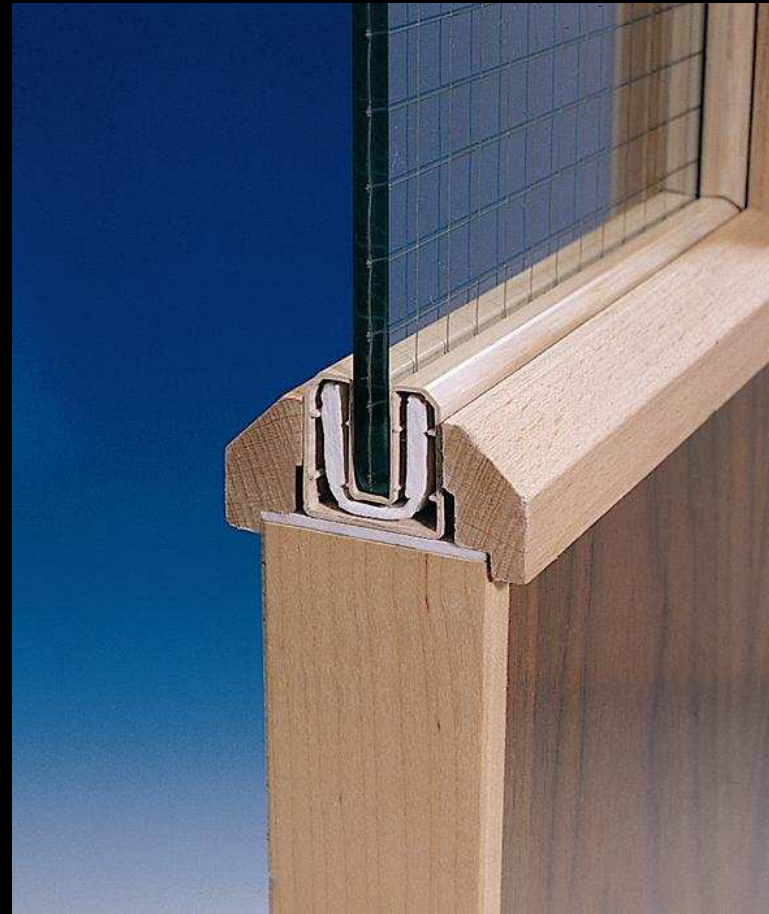

# Fire Resisting Glazing

## Largest Panes of Pyroshield Achieve 64 Minutes

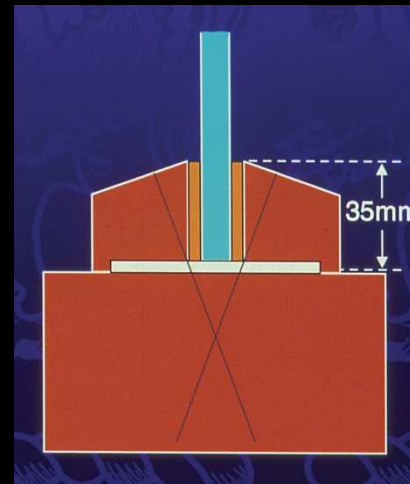

Intumescent compound & liner  
with large beads

# Fire Resisting Glazing

Largest Panes of Pyran Achieve 74 Minutes

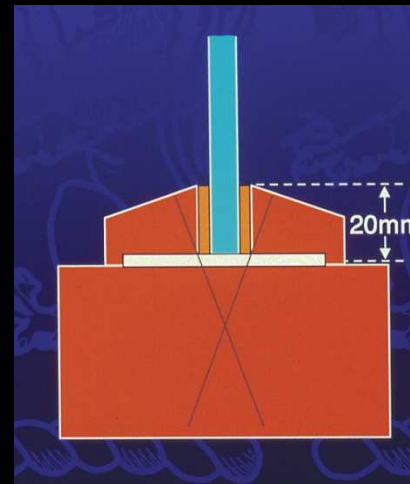

Intumescent compound & liner  
with small beads

# Fire Resisting Glazing

Pyran Butt Joint System Achieves 36 Minutes

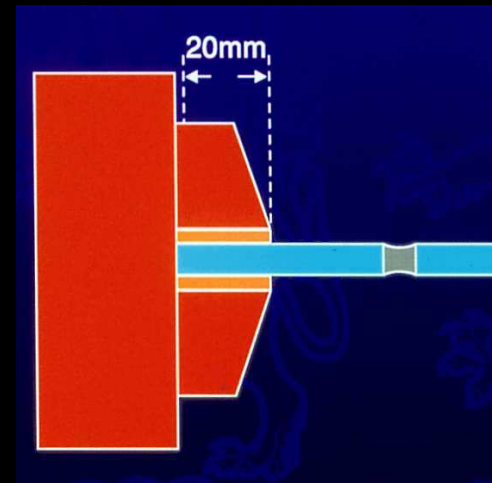

Intumescent compound  
with no mullion

# Fire Resisting Glazing Butt Joint System



# Fire Resisting Glazing

## Butt Joint System



# Fire Resisting Glazing

## Mock Georgian Glazing Bars

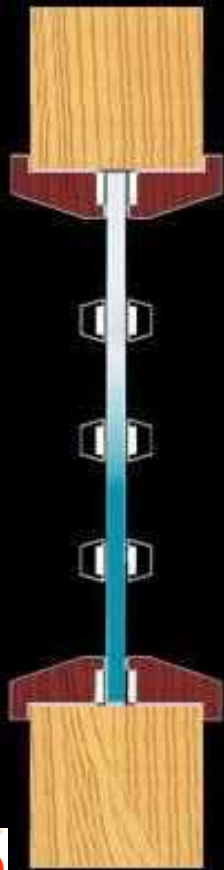

- Standard glazing bars too small.
- Mock glazing bars fixed to glass with intumescent strip behind.
- Strip forces bars from glass in fire leaving large pane.
- 30 & 60 minute fire resistance .

# Fire Resisting Glazing

## TYPES OF FIRE RESISTING GLASS

### Uninsulating glasses

- Glass expands on heating.
- Beads create cooler areas
- Temperature differential created.
- Temperature differential tolerance varies between glasses.
- 'Edge cover' is critical.

# Fire Resisting Glazing

## TYPES OF FIRE RESISTING GLASS

### Insulating glasses

- Able to meet BS476 Part 20 requirements.
- Laminated glass/intumescent layers or,
- ‘Gel’ sandwich between 2 glass layers.
- Generally thicker and heavier than uninsulated glasses.

# Fire Resisting Glazing

## Glazing System Components

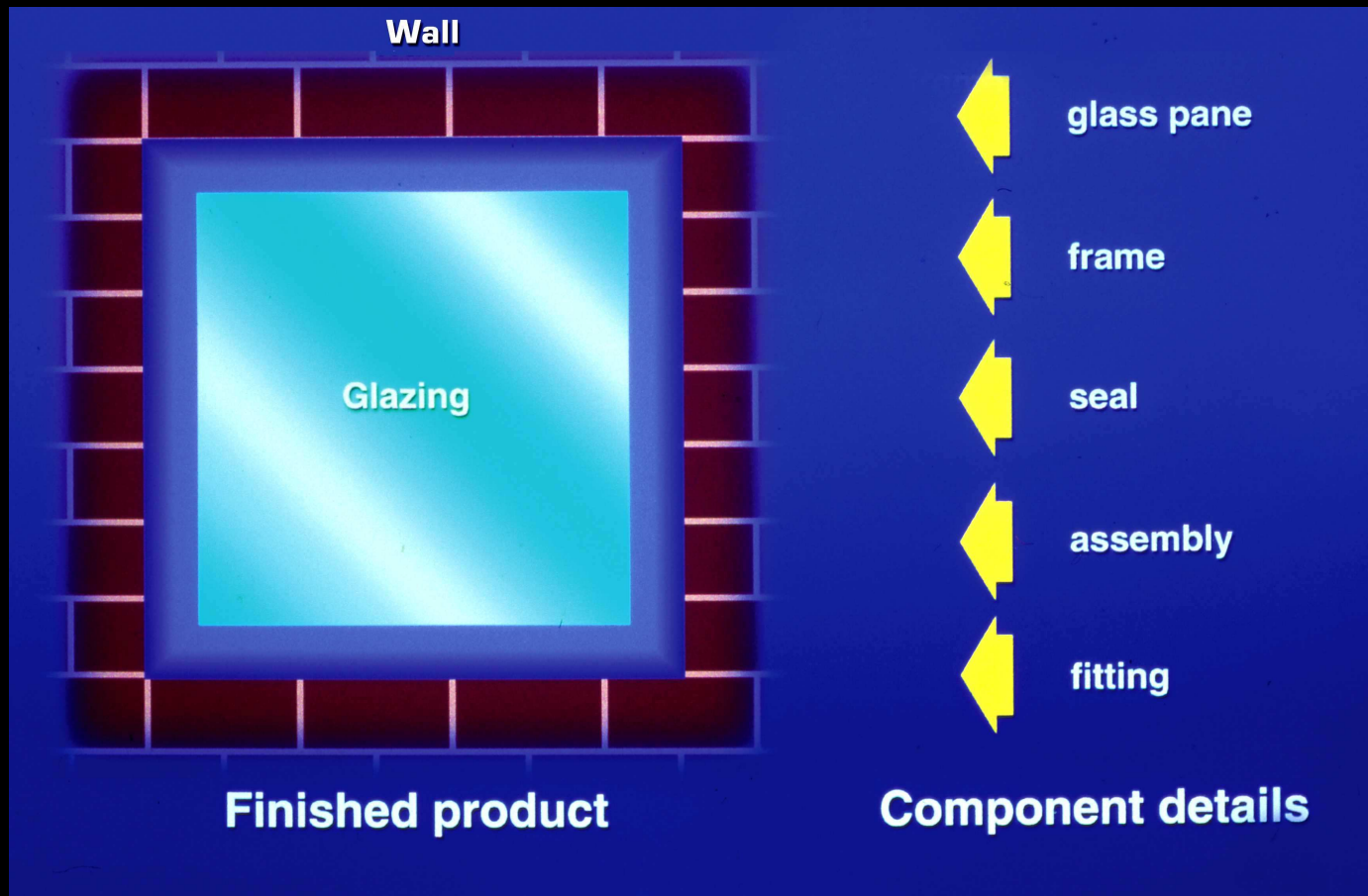

# Fire Resisting Glazing

## CONCLUSION

- Test evidence must reflect the application.
- GGF (Glass and Glazing Federation)
- IFSA (Intumescent Fire Seals Association)

# INTUMESCENT TECHNOLOGY IN FIRE RESISTING GLAZING

